

# VST inc

## Precision Filter Basket

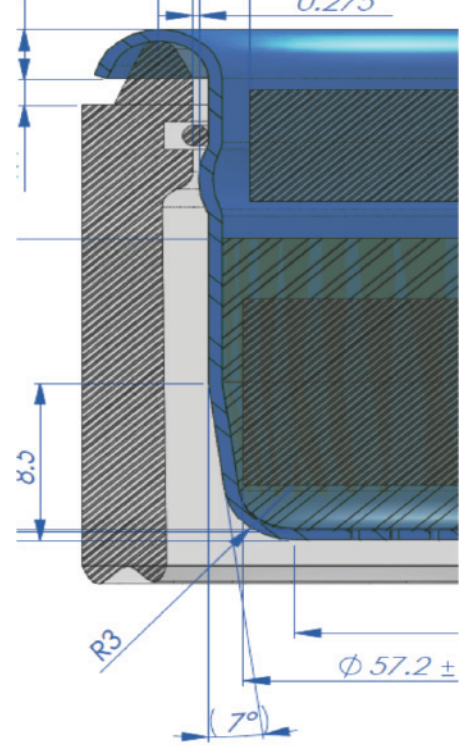

Improved Espresso Quality

Precision Fabrication

Area

- Circularity

- Uniformity

Hole Placement

Hole Geometry

Superior Material

Capacities

Compatibility

Genuine Article

- Performance Grade

VST Warranty

Food Safety Certifications

VST's new filters deliver consistent extraction performance over a wide range of concentration with reduced sediment.

All VST Filters are WARRANTED for ZERO DEFECTS  
Holes are fabricated using a new micro-machine and finishing process.

100% of holes are measured on every filter for min/max range limits on area and diameter to a precision of +/- 30 µm

All holes are measured for circularity, placement, square area and blocked holes

Filters are matched for total square area opening to +/- 5% to ensure identical performance. (typical filters vary from -50 to +100%)

Hole pattern is centered to +/- 1.0 mm and placement is oriented for uniform extraction throughout the entire puck

Wide outlet angle to prevent filters from clogging, anti-wear design ensures uniform performance for life of product.

Improved structural integrity, will withstand deflection from pump cycling without premature fatigue failures (see VST Warranty).

### Capacities and Dimensions

| VST Filter   | Dose (g) | Height (mm) | Dia (mm) |
|--------------|----------|-------------|----------|
| 22-g Triple  | 21-23    | 28.0        | 60.0     |
| 18-g Double  | 17-19    | 24.2        | 60.0     |
| 15-g DBL-EUR | 14-16    | 22.0        | 60.0     |

Designed to fit with most 60mm Portafilters.

(see DIMENSIONS, above and VSTAPPS.COM site for more details)

Recommended Tamper: 58.2-58.4mm diameter, flat face.

Each VST filter is marked with a unique 2-D code to ensure authenticity and performance. 2-D code stores factory measurement, quality reports and image data.

Each filter is graded and warranted to perform identically to similar grades

Each genuine VST filter is warranted to meet or exceed published specifications for one year or will be replaced free of charge

RoHS; ECHA REACH; EU GENERAL - German, Italian, French; US FDA



## Available To Purchase Now

[www.vstapps.com](http://www.vstapps.com)